

# SECONDARY COMPONENTS

English

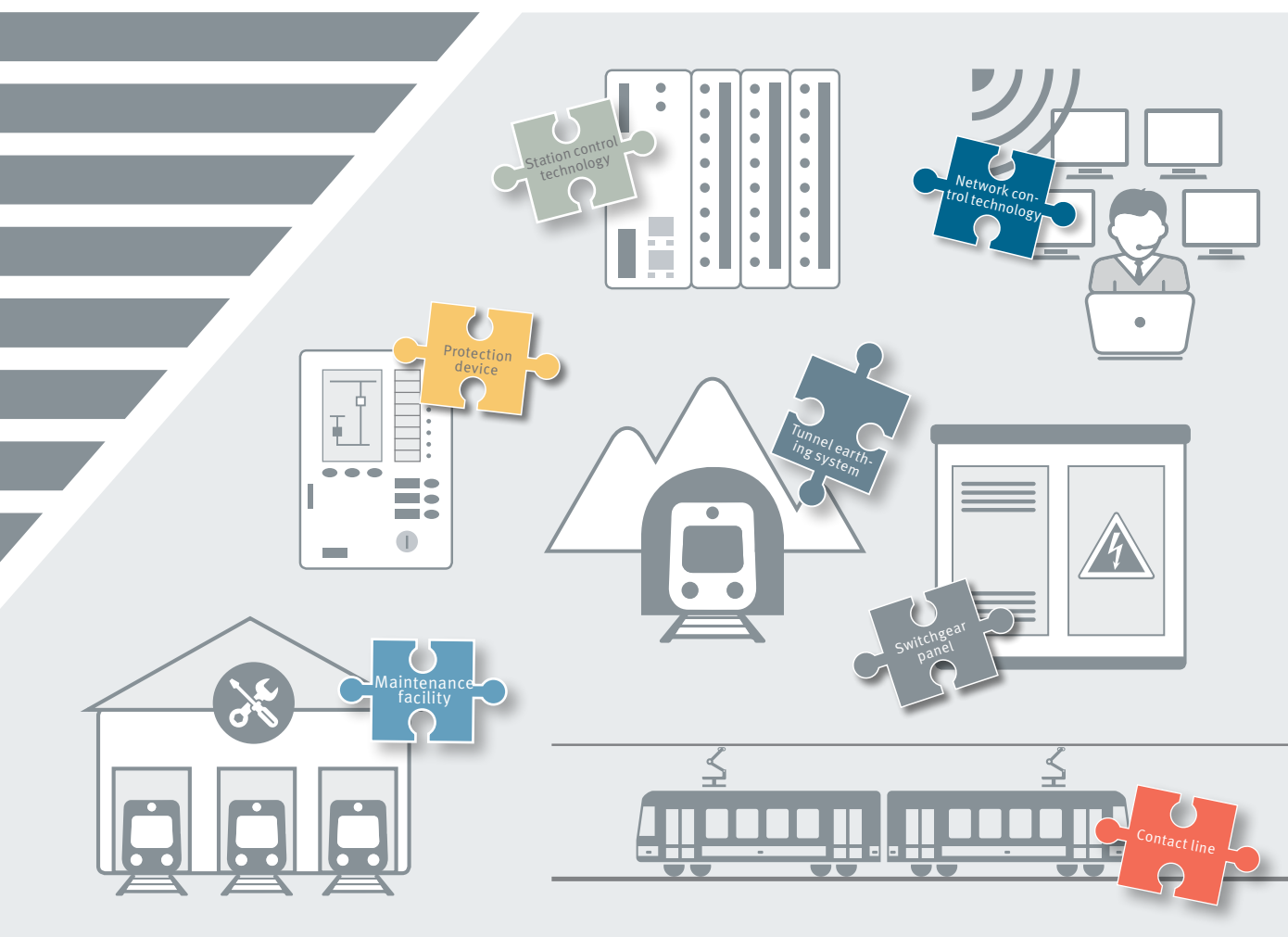

Products and services for protection and control technology

## BRINGING PEOPLE SAFELY AND PUNCTUALLY TO THEIR DESTINATIONS – BY MEANS OF EFFICIENT AND ENVIRONMENTALLY FRIENDLY ELECTRIFIED TRANSPORT SYSTEMS

This requirement is essential for the innovative solutions of Rail Power Systems. We aim to pave your way to the sustainable mobility of the future with our specialist knowledge and proven technical concepts.

The name Rail Power Systems stands for high performance railway infrastructure projects that reconcile ecological considerations with economic benefits. Energy efficiency, investment protection, easy and quick maintenance, the occupational health and safety initiative SAFE TOGETHER and assuming responsibility for the community are extremely important to us. We also focus on durable products, solid quality and a high integration depth.

At Rail Power Systems you are able to consult experienced experts from a variety of disciplines, who will provide you with solution concepts that have modular structure and are planned systemically. Furthermore, you will receive tried and tested product platforms that meet the high level of efficiency required by customers

## A RENOWNED PARTNER FOR RAILWAY ENERGY SUPPLY SYSTEMS



The inverter station of DB Energie Lohsa-West

Local and long-distance public passenger transport services have experienced strong growth rates worldwide and contribute to the reduction of climate-damaging greenhouse gases and, accordingly, to the protection of the environment. In future, rail transport companies will need to be ready to deal with increasing volumes of traffic and the associated challenges. Rail Power Systems has more than 125 years of experience in the field of supplying power to railways and will advise, accompany and support you as the system supplier. Due to our comprehensive product range and exceptional system expertise, we are able to provide you with optimum solutions tailored to your requirements.

- For local and long-distance transportation
- For the installation of new lines or the renovation (retrofit) or enhancement of an existing infrastructure
- With studies for the system design
- From the planning and delivery to the commissioning of the system components
- Including service during operation until modernised

The brochure focuses on products for protection and control technology. It also provides an overview of other Rail Power Systems products and services for railway electrification systems.

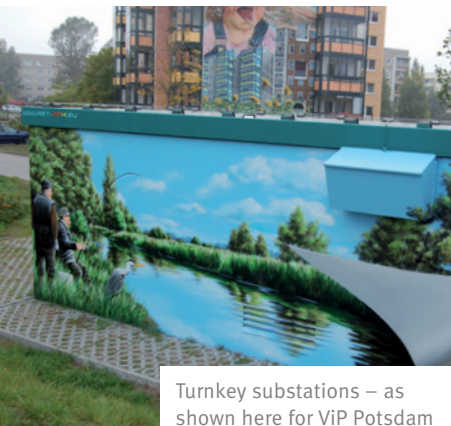

Turnkey substations – as shown here for ViP Potsdam

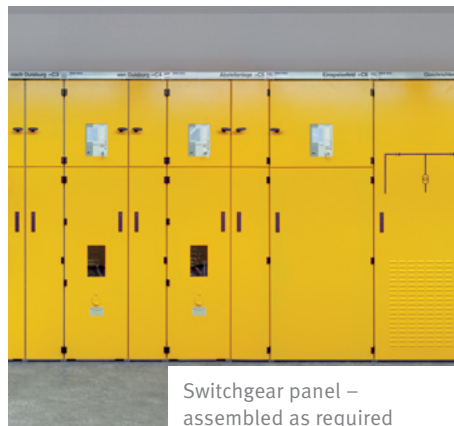

Switchgear panel – assembled as required



Contact line systems – designed as overhead line

## RAIL POWER SYSTEMS COMBINES ALL THE NECESSARY COMPONENTS FOR A COMPLETE FUNCTIONAL SOLUTION

Rail Power Systems is able to provide all the necessary services to design, build and maintain the complete infrastructure of a local transport system. In this regard, we are able to supply all the required components and systems.

Do you need individual service modules? No problem! Here too we can also provide an appropriate solution for you. In doing so, we coordinate the individual subservices (such as modules) with regard to the overall system. All of the subservices can then be later combined to form an optimal whole.



## PROTECTION UND CONTROL TECHNOLOGY PRODUCTS

Our core products for protection and control technology are impressive as individual modules and as a system

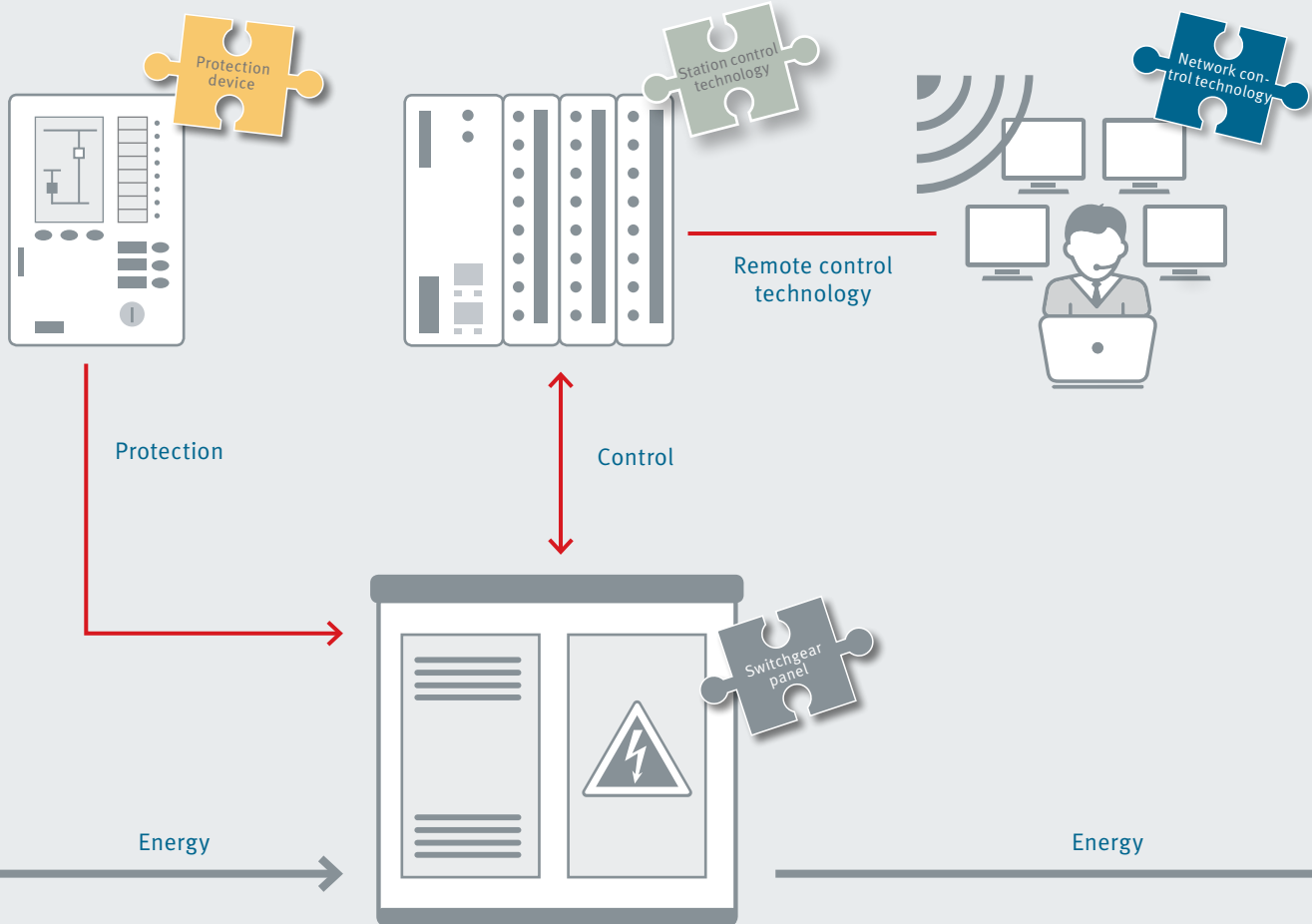

## WE WILL SUPPORT YOU FROM THE BASIC PLAN TO THE MAIDEN VOYAGE ... AND WILL GLADLY ALSO INCLUDE SERVICING AND MODERNISATION

In the planning, design and configuration of the specific technical solution, we are guided by you – regardless of whether this relates to the components, the switchgear panel or the entire system, whether in relation to far-sighted design planning or configuration, the delivery and turnkey handover of the entire system or professional maintenance/retrofitting in operation inclusive of disposal at the end of the service life.

Rail Power Systems is your reliable partner for:

- Well-founded systems analyses
- Tried and tested components and systems based on the TracFeed® product range
- Comprehensive services during operation up to the professional dismantling and disposal of the systems

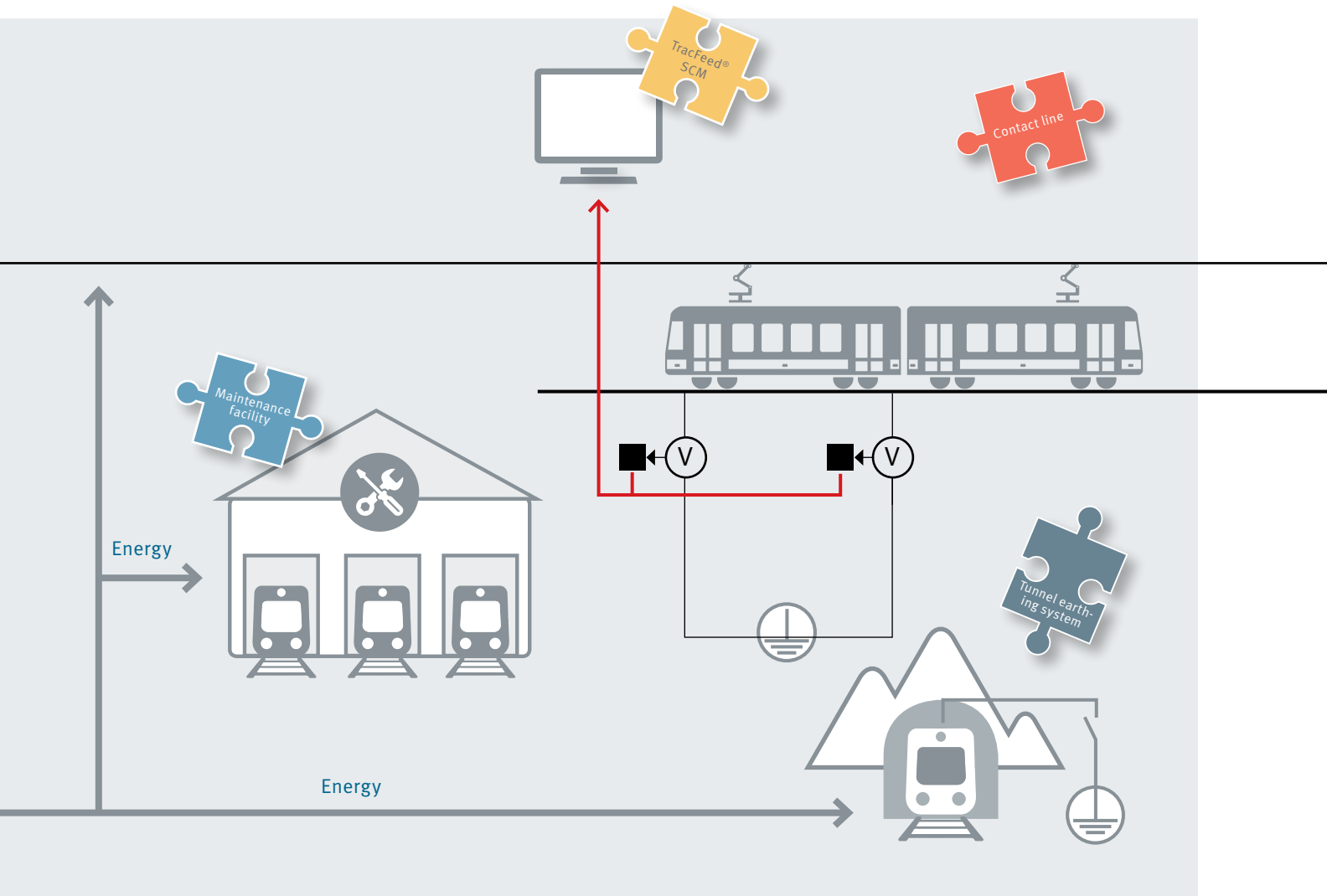

## OUR EXPERTISE – PROVEN IN DEMANDING REFERENCE PROJECTS

Sustainable, reliable and ecologically responsible mobility represents one of the central challenges in or between the many centres and large metropolitan areas. Highly efficient passenger and freight transportation will play a decisive role in solving these tasks today as in the future.

Whether you are currently planning a comprehensive, large-scale transport project for the future or whether you are concentrating on specific areas of focus: You can rely on the know-how and the many years of experience of the experts from Rail Power Systems. Our expertise has proven itself in many challenging reference projects in Germany and numerous other countries. We can accordingly support you individually and success-oriented.



## SYSTEM DESIGN – THE BASIS FOR TAILOR-MADE RAILWAY ENERGY SUPPLY SYSTEMS

As an expert specialist for electric railway infrastructures, System Design plays a key role in ensuring that users of the infrastructure are able to enjoy reliable and secure mobility. Our experienced specialist engineers apply their exceptional know-how as well as decades of experience, state-of-the-art computer applications and simulation systems to analyse all relevant aspects which affect the system.

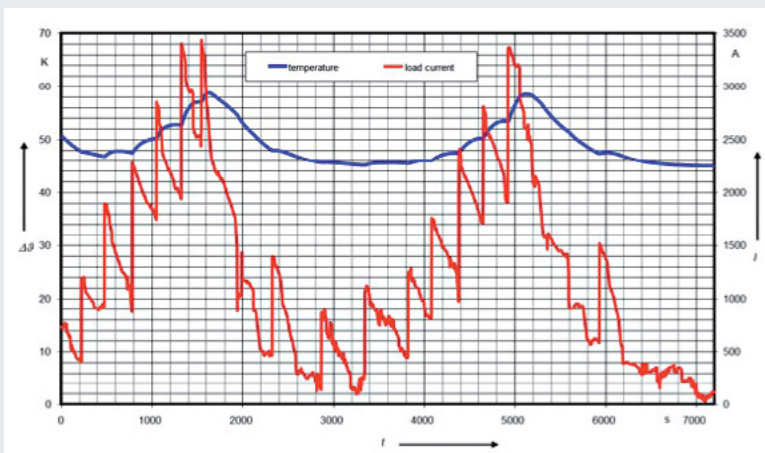
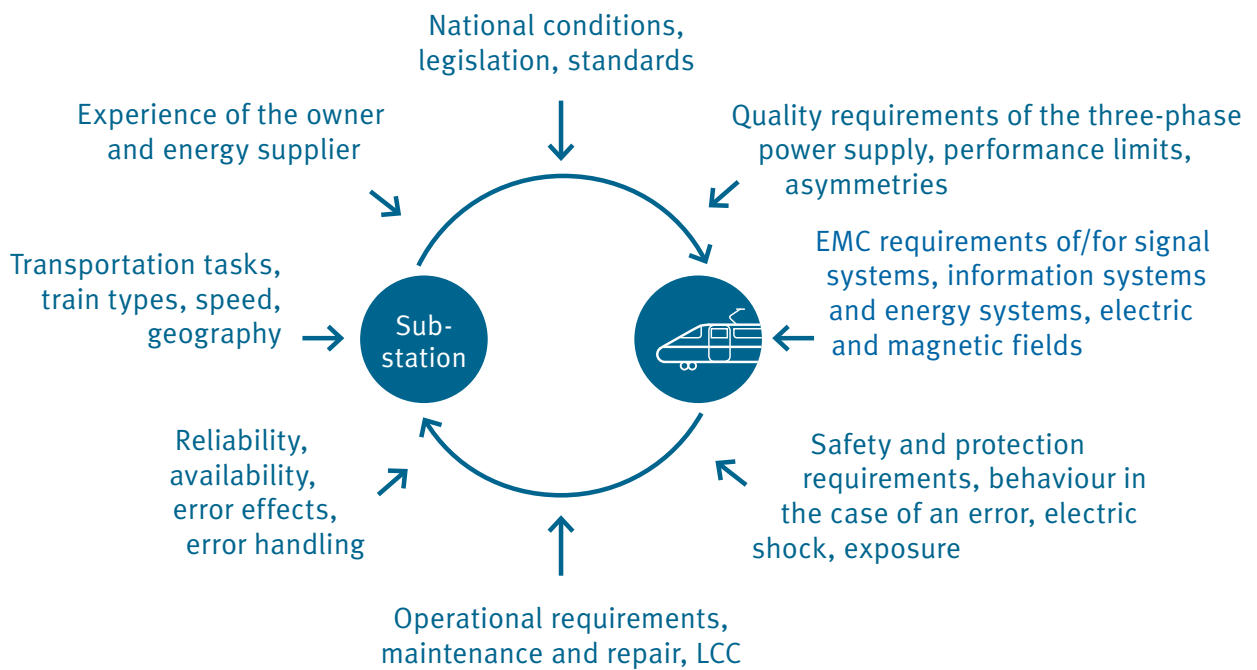

Temperature profile and load current of an overhead contact line



Rail Power Systems is your expert partner for optimal system solutions – we have a diversified spectrum:

- Creating IT security concepts
- Calculating the dynamic load flow of meshed networks
- Designing railway power supply systems
- Analysis of weak points
- Electrical network conversions  
(e.g. DC 6,900 V to DC 750 V, 1.5 kV to 3 kV)
- Determining protection concepts
- Demonstrating possible solutions
- EMC calculations
- Earthing and return current circuit
- RAMS analyses
- Dynamic simulation of overhead conductor rails and overhead contact lines with TracFeed® OSSCAT

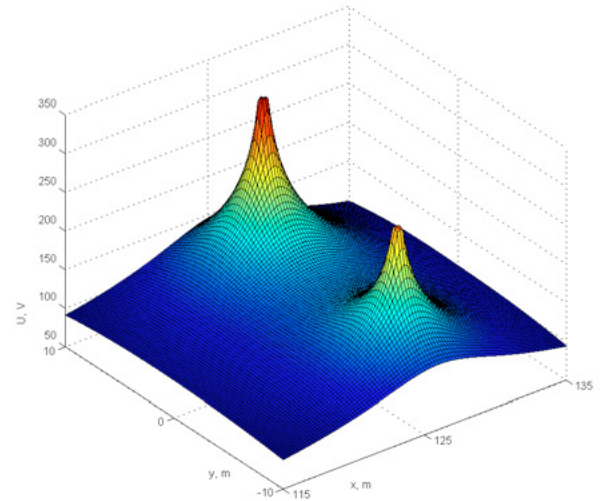

Earth surface potential in the event of a short-circuit due to a flashover of an insulator on the mast

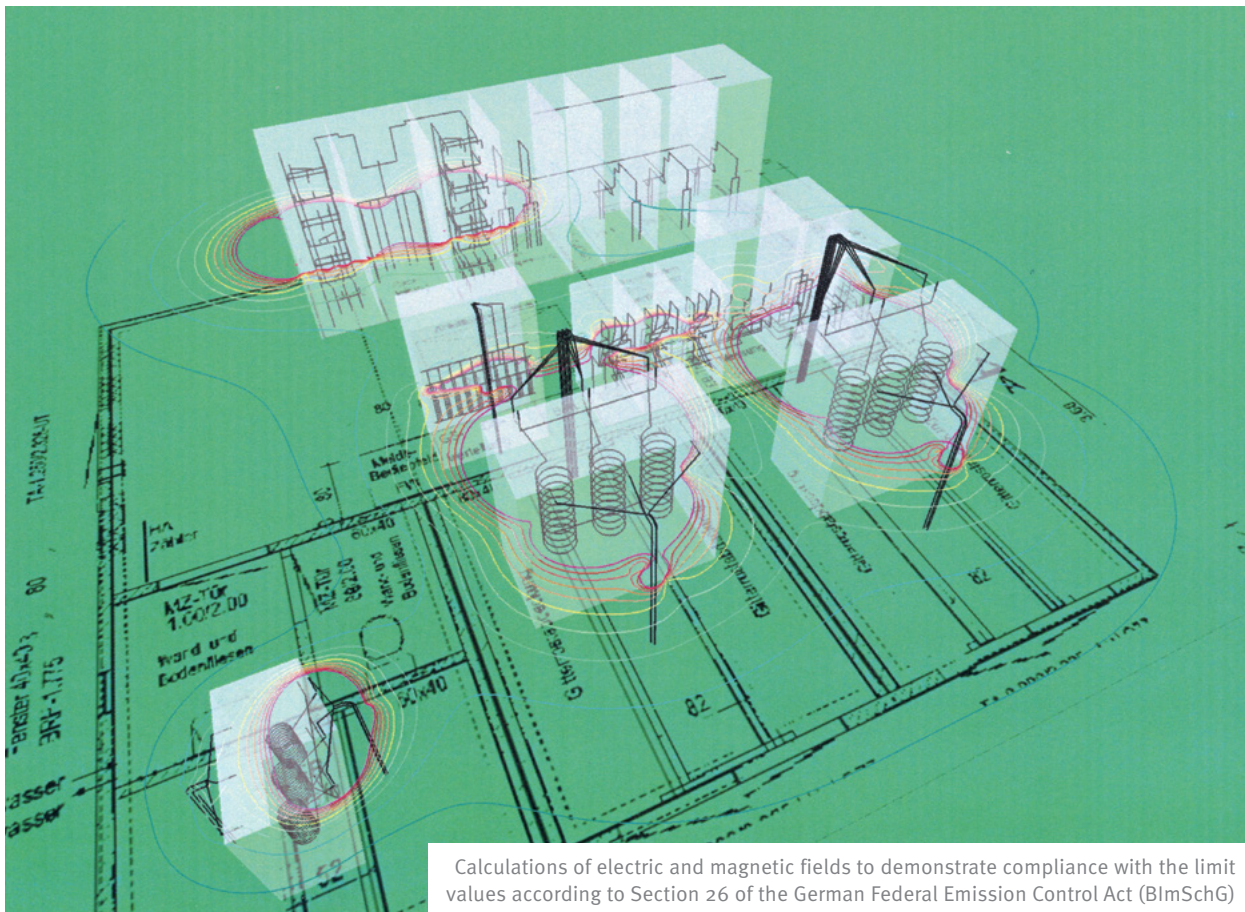

Calculations of electric and magnetic fields to demonstrate compliance with the limit values according to Section 26 of the German Federal Emission Control Act (BImSchG)





## STATION CONTROL TECHNOLOGY IN EVERY REQUIRED BANDWIDTH

The station control technology enables the central substation control. The spectrum ranges from the Ethernet fieldbus system for various communication protocols (including IEC 60870-5-104 and IEC 61850) to the redundantly designed central PLC. The station control system also includes the interface to the network control technology and is available in various power levels. An industrial PC, as a local HMI (human-machine interface), enables the convenient operation of the switchgear panels and the archiving of signals.

Does your station control system also need to cover extensive special applications, e.g. for depots (a safety PLC for roof work platforms etc.)?

**We also have professional solutions for such tasks!**

### Substation 1

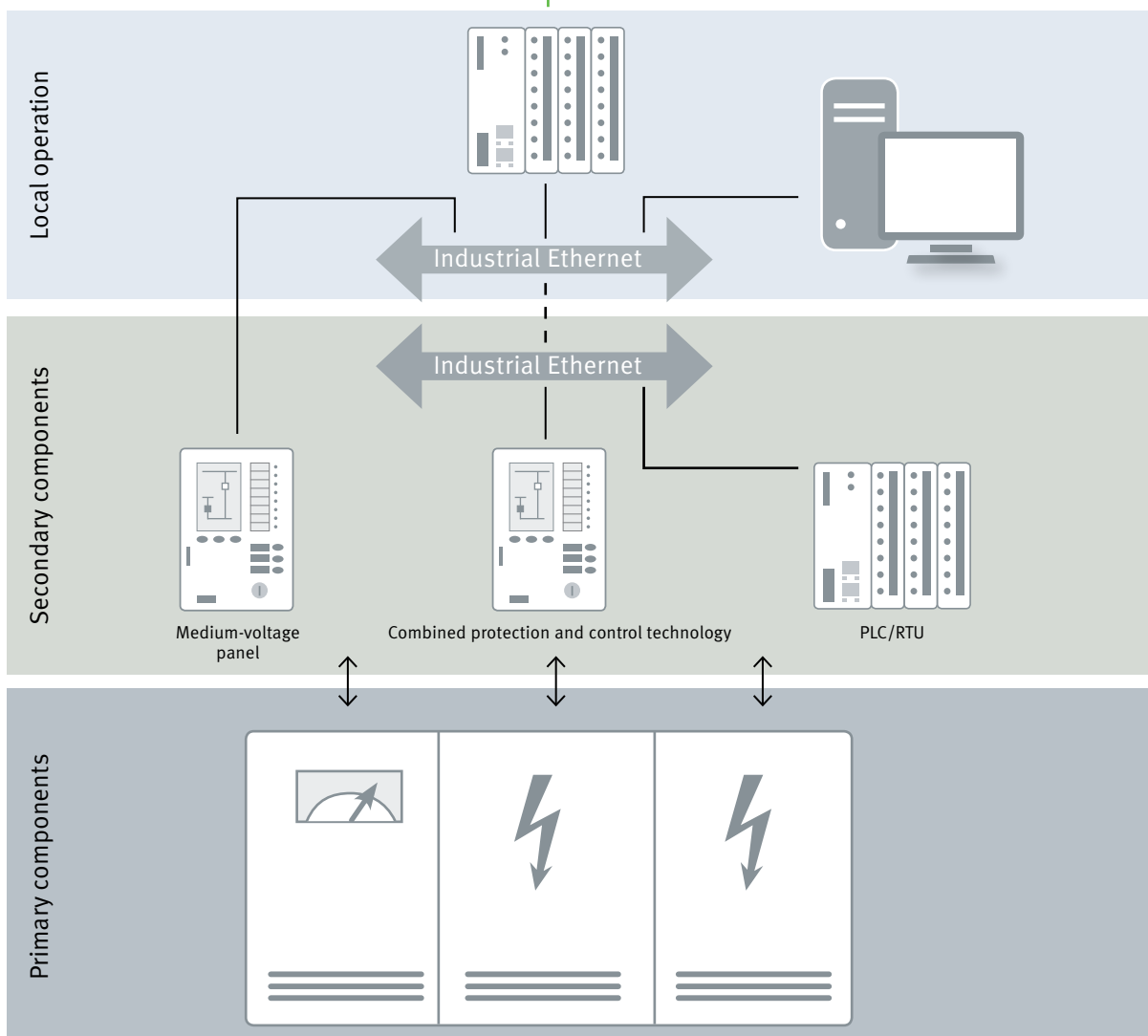





## STATE-OF-THE-ART NETWORK CONTROL TECHNOLOGY

**When it comes to sophisticated products for maintenance and control technology, Rail Power Systems is the best partner you can choose.**

From control components via optical transmission paths and redundant lines to the control centre: we provide a wide range of network control applications for implementation in systems customised to meet your requirements. In addition to remote control connections according

to international standards, such as IEC 60870-5-101/-104, we can also integrate existing remote control lines with manufacturer-specific protocols. In the process visualisation for the human-machine interface (HMI), we attach particular importance to the design of the user interface – and above all on user guidance and ease of use of the control, monitoring, archiving and evaluation of your rail energy supply systems.

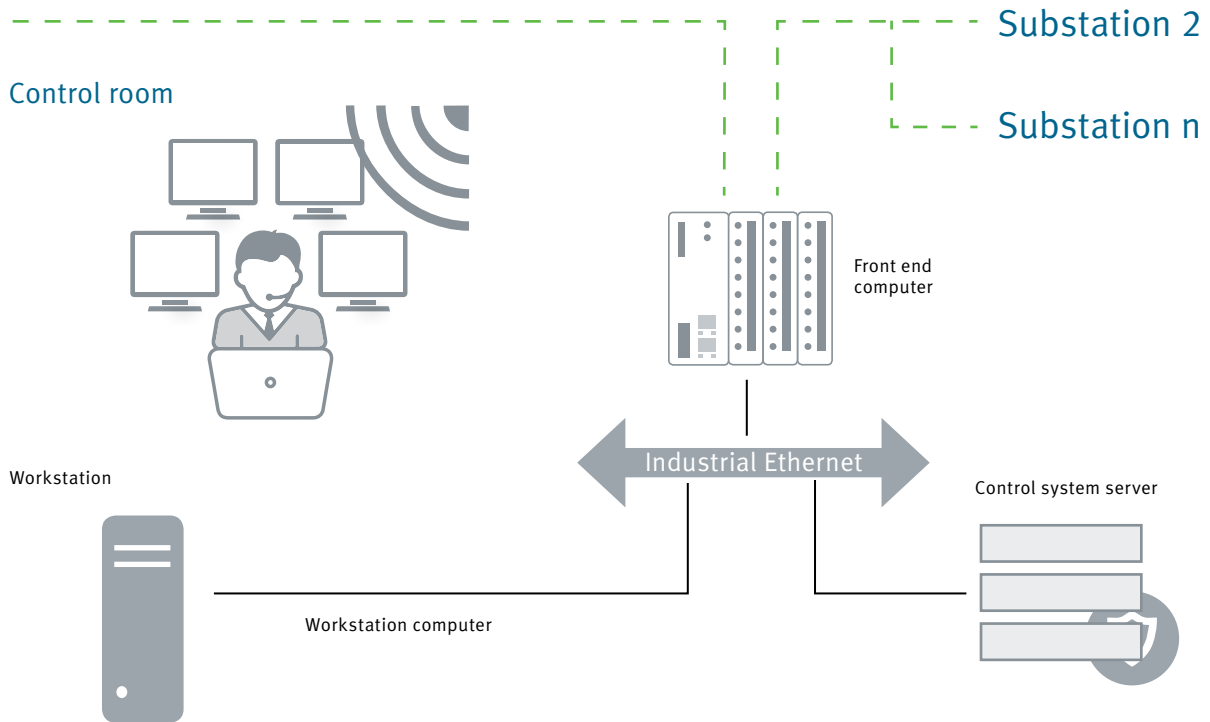

Network control room, Shanghai



## IT SECURITY

The IT systems of railway energy companies are subjected to numerous threats. The risk of a harmful incident increases with the complexity of the systems and connections to external IT networks. Rail Power Systems offers secure, efficient and economical solutions for IT security in the rail energy environment to minimize risks. The IT security solutions have been developed in compliance with the German IT Security Act, the IEC 27001 series of standards, the IEC 62443 standard and the white paper of the German Federal Association of the Energy and Water Industry (the BDEW) on the requirements for secure control and telecommunications systems, and are constantly being adapted to new requirements.

### Secure remote access

Secure remote maintenance access allows independent maintenance and service technicians to gain insight into the control of a railway energy system from a distance. This supports easy diagnostics and troubleshooting. If an attendance on-site is necessary due to a fault, this can be prepared for in a targeted manner by means of a remote fault analysis.

- Secure system architecture based on the recommendations of the BDEW white paper and the standards of the ISO 27000 series
- (Improved) client-compatible remote access for complex energy systems
- Central access portal with three-factor authentication
- Self-sufficient IT infrastructure on the site
- Modular
- Scalable
- Independently of the system manufacturer
- Multi-level authentication
- Active malware protection
- Administration as a service

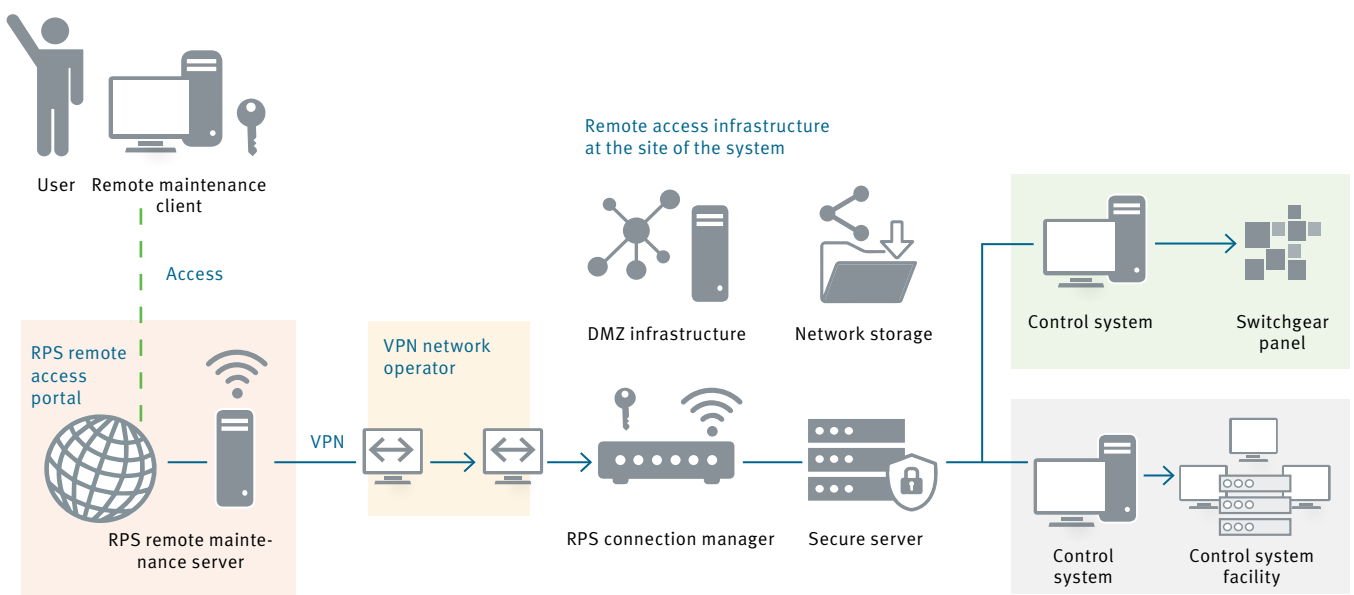

## Remote access

For smaller control system facilities that are not subject to the requirements of the German IT Security Act, Rail Power Systems offers a secure and economical solution for direct remote access.

- Industrial VPN infrastructure
- Central remote maintenance server
- Central authentication
- Mobile and stationary solutions

## System hardening

The IT components in control system facilities need to be hardened for secure operation. System hardening follows the principle of “defence in depth” in which all the IT components of a system are protected in multiple layers against unauthorised access and harmful influences.

- Creating a secure infrastructure
- Compliance with BSI and best practice requirements
- Operating system hardening
- Active malware protection
- Secure networks
- Operational training

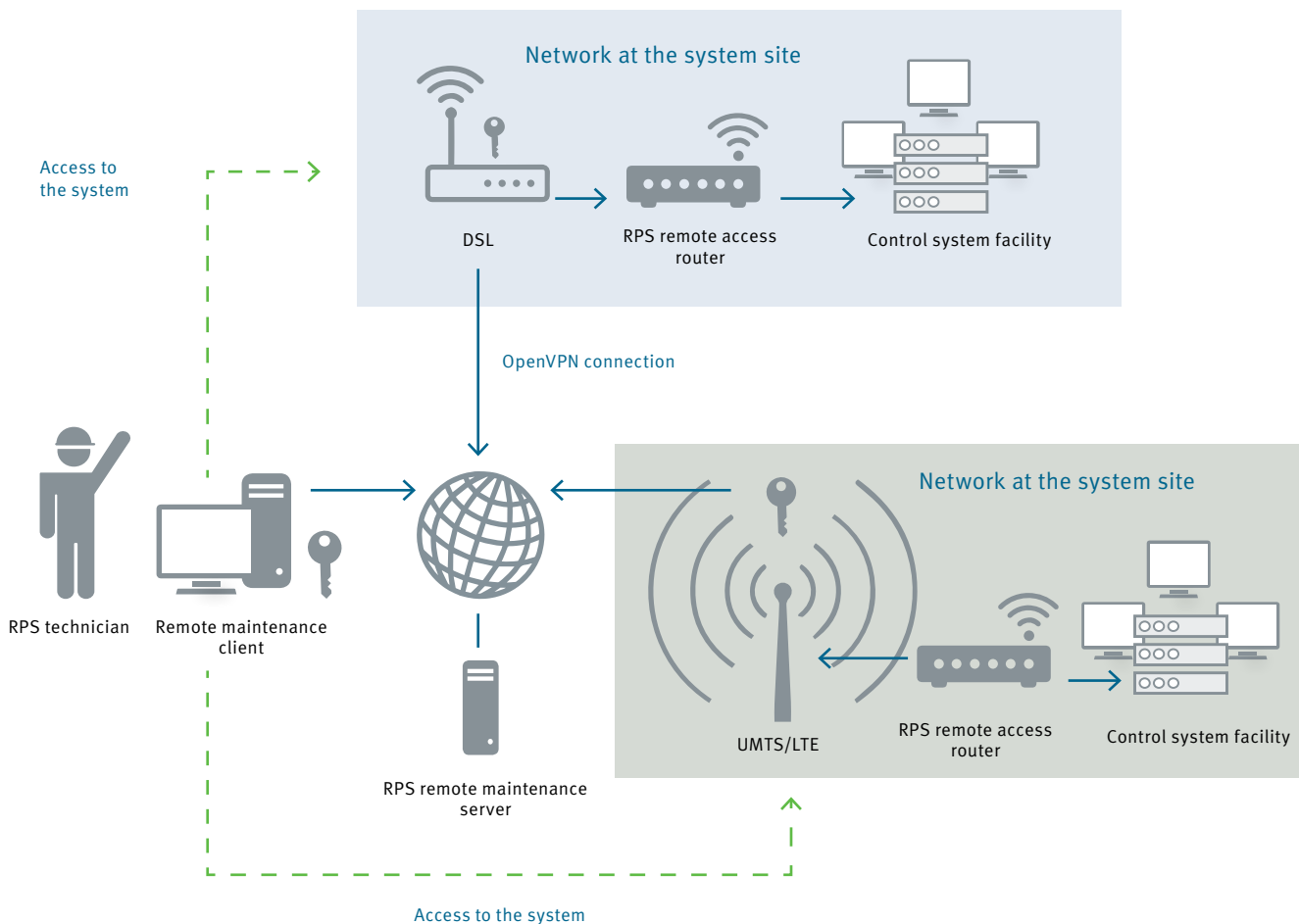

## PROFESSIONAL SYSTEM PROTECTION

Rail Power Systems has gained extensive expertise in the field of system protection as a result of many years of experience in the field of railway energy supply. From the initial network study for the establishment of an appropriate protection concept to the design and construction of the corresponding system components, commissioning, training and analysis of network faults, Rail Power Systems can provide you with the appropriate solution in all these areas.

In designing the system protection, we are manufacturer-neutral in the choice of components or use our own products of the TracFeed® DCP family in the area of DC switchgear panels for system protection and control.

### TracFeed® DCP – Functions of the switchgear panels

The primary task of the DC switchgear panels as part of the railway energy supply is to feed the traction energy (for the vehicles) into the contact line network. The contact line system is subdivided into feeder sections (lines). This enables the selective protection of the individual sections. Rail Power Systems uses the multifunctional devices of the TracFeed® DCP device family for all tasks concerning the protection of the lines and systems as well as for control and communication.

### Convenient display and operation

The TracFeed® DCP2 visually presents all available information clearly in its large display. In addition to the graphic display of the mimic diagram with the switchgears, these can also be selected and switched. Plain text displays can be invoked using context-sensitive buttons, e.g. settings, measurements, event lists. The coloured LEDs to provide important signals independently of the display have proven themselves on numerous occasions. Assignment and colour (red or green) of the LEDs can be set freely and adapted to your specific operating conditions.

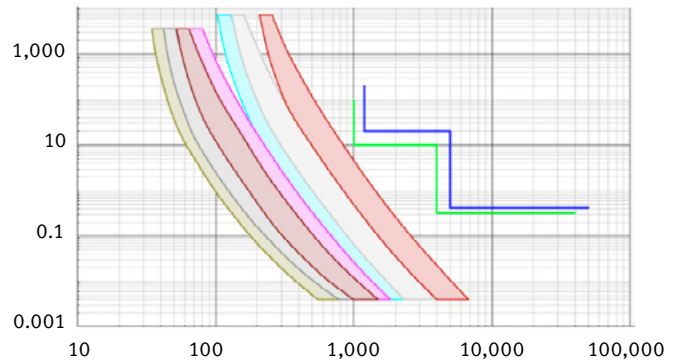

### Protection functions if the worst happens

The TracFeed® DCP2 protects your operating equipment using various protection functions operating in parallel. These range from short-circuit protection in the milliseconds range to thermal inverse protection in the hours range.

### Control functions

Control functions make it possible to reliably detect and execute the switching commands for electrically operated switching devices. In addition to locally controlling a DC switchgear panel, the remote control of switchgears can also be easily performed. The integrated key switch enables the changeover between local control and remote control. Using interlocking functions, it is reliably ensured that unauthorised switching commands cannot be executed. This applies to all switchgears that are controlled by the TracFeed® DCP2.





## TracFeed® SCM – STRAY CURRENT MONITORING SYSTEM

As a rule, deliberate connections between the return circuit and earth are avoided in DC railways. However, the return circuit cannot be completely isolated from the earth. The partial current that flows via paths other than the return circuit is called stray current. Stray current can cause corrosion with the subsequent destruction of metal structures in a railway environment. Overheating, arcing and fire are further potential risks due to stray current, with potential danger for persons. The direct measurement and monitoring of the stray current flowing out of the tracks is practically impossible. The standard DIN EN 50122-1:2011 thus recommends monitoring the rail

insulation. This can be done by arduously taking manual measurements at regular intervals or by means of a continuous monitoring system such as the TracFeed® SCM

### Protecting the infrastructure

The TracFeed® SCM monitors your infrastructure around the clock. Along the route the relevant information is collected and sent to the central evaluation unit. The information received on the infrastructure is condensed, evaluated and visualised in the central evaluation unit.

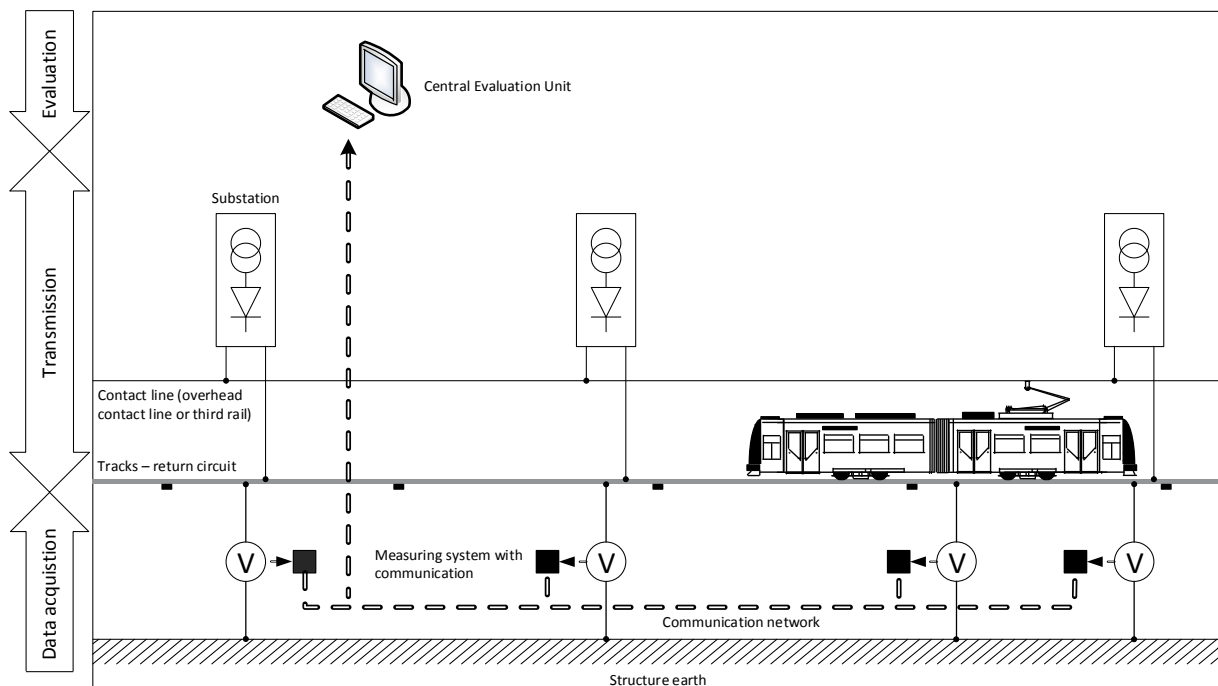

### Everything at a glance

Due to the user-friendly visualisation, you can determine the status of your system at a glance. You will be informed immediately about any significant changes in your system and will be able to start the fault clearance process promptly. The archiving function makes it possible to analyse the development of the error.



## SYSTEMS FOR THE AUTOMATED EARTHING OF CONTACT LINE SYSTEMS

With Rail Power Systems, you will receive important impulses and useful ideas, also for the quick and easy maintenance of your railway systems in the long term. For example, we are ready with know-how for the smooth interaction of your infrastructure with the rolling stock.

How can one reliably control a switchgear panel and a downstream contact line switchgear panel for the supply of a depot? How can an additional advantage for occupational health and safety be guaranteed in the workshop by means of safety-related technology?

We are your proven partner for these and many other questions to make rail energy supply even safer and more economical.

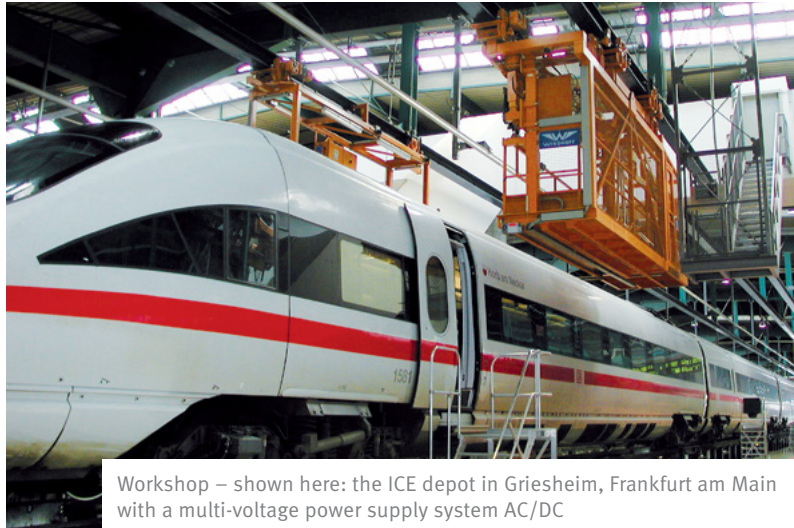

Workshop – shown here: the ICE depot in Griesheim, Frankfurt am Main with a multi-voltage power supply system AC/DC

### Scope of delivery

- Planning
- Installation
- Commissioning
- Acceptance
- Service
- Maintenance

### Standards

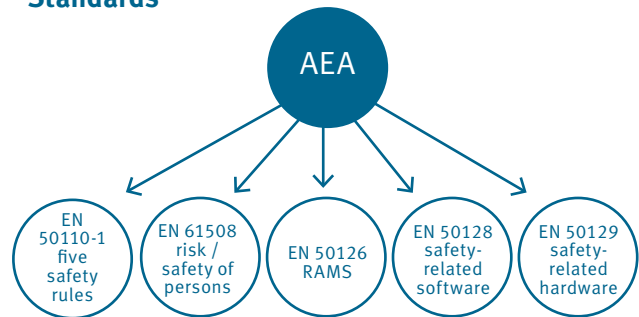

### Setup

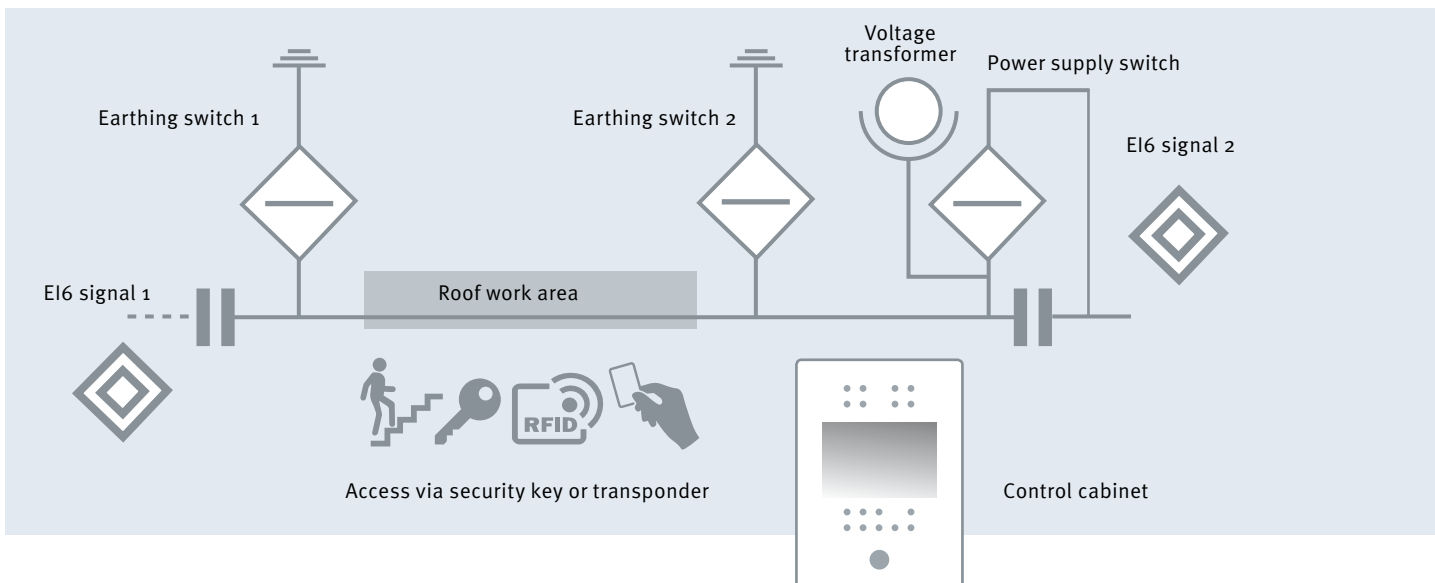

## AUTOMATED SWITCH-OFF AND EARTHING SYSTEM TracFeed® AEA

### Functions

- Automatic earthing and switching on the catenary
- Implementing the five safety rules according to EN 50110-1:2013 or VDE 0105-1
- Emergency shutdown
- Protection of persons by means of access control
- Interlocking with other system parts
- Controlling El6 signals
- Diagnostics, event list (operating log), alarm list, system visualisation

### Certification

- SIL 2 certification achieved for the large wagon hall project at Rummelsburg



### Combinations

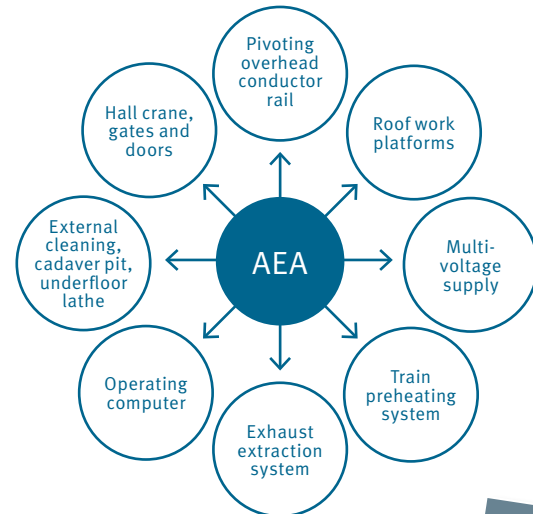

## EXPERTS FOR DEPOTS AND WORKSHOPS

Working on and in the area of contact line systems involves numerous dangers. Maintenance and cleaning work on railcars or trains must be capable of being carried out in compliance with the five safety rules in a timely manner and without endangering the personnel. In this regard, a complete solution for the safety-oriented control and monitoring of the contact line system is indispensable, especially in the work area.

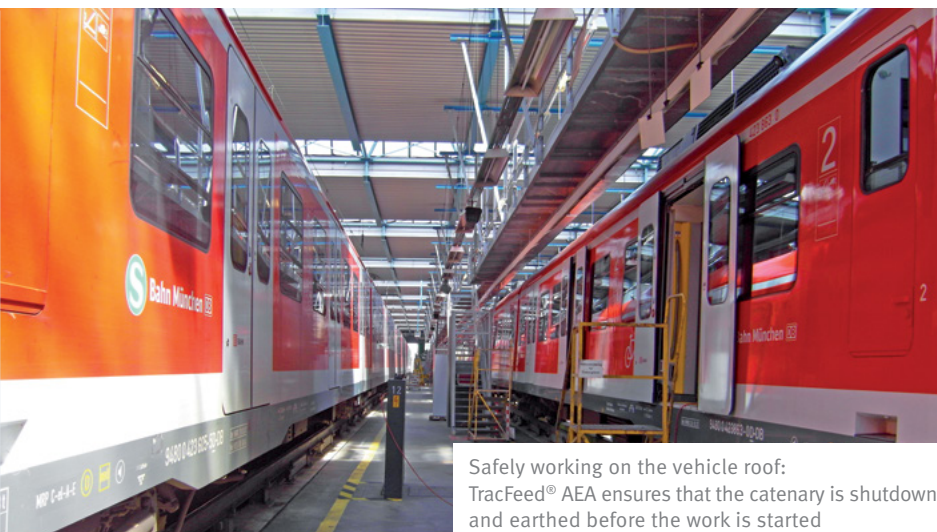

Safely working on the vehicle roof: TracFeed® AEA ensures that the catenary is shutdown and earthed before the work is started



Constant status information about the system and key-based interlocking functions



## TracFeed® OLSP

### The task

In the event of an accident in a railway tunnel, the passengers and rescue workers are exposed to numerous dangers. Especially in the event of a fire, the rapid evacuation by means of self-rescue and the assistance of third parties is crucial, since the greatest harm can be avoided within the first 15 minutes after the occurrence of an event.

A live or not yet earthed catenary constitutes an additional danger and can significantly delay the deployment of rescue teams. Thus, external rescue measures cannot begin in a tunnel until the rail operator has switched off the catenary system and it has been properly earthed on-site. Especially manual earthing by rescue workers, i.e. usually electrical laymen, is a time-consuming and unpopular task that takes up even more precious time. This is even more so in extreme situations and when the power status of the catenary is initially unknown.

The TracFeed® OLSP ensures that an automated emergency earthing takes place which:

- Checks that the catenary is no longer live
- Carries out the earthing process automatically
- Verifies that the earthing at the tunnel portals was successful, as well as
- Displaying the safe condition of all tunnel accesses to the emergency services



### The control panel

TracFeed® OLSP control panels are installed to be readily accessible at all tunnel access points, i.e. at the portals and all rescue access points. The control panels consist of three indicator lights (red, green and yellow) and a control button. The indicator lights signal the condition of the catenary, and the control panel can be used to trigger an emergency earthing if the remote command could not be used to trigger earthing (e.g. communication to the central switching point was interrupted).

### Reliability

As a safety-related system, an automated emergency earthing system must meet high standards with regard to error-proofing and availability. Thus, persons must not be endangered by incorrect indicator signals under any circumstances. The TracFeed® OLSP has been developed in accordance with European regulations and directives as a reliable, highly available and easy-to-maintain system. It was subsequently certified by an independent assessment body.





## System overview

The TracFeed® OLSP as an integrated, functional product consists of two parts: the control unit and the components of the catenary system. Rail Power Systems is able to offer all the components and services required for an OLSP system from a single source. This has the advantage for the client of being able to coordinate the requirements of the entire OLSP system with a single contact person.





## Flexible

TracFeed® OLSP can be used with minor adjustments with all known grid types. It is universally operable in 16.7 Hz, 50 Hz and DC networks, for example as TracFeed® AEE in the cross-city link in Switzerland or in the DC systems of Mainz.

- DIN EN 50126
- DIN EN 50128
- TSI SRT



## OLSP - Kurzbeschreibung für die Feuerwehren

Anzeige der OLSP	Bedeutung der Anzeige
alle Anzeigen dunkel 	<b>Lebensgefahr</b> Die Oberleitung ist nicht abgeschaltet und steht unter 15 000 V Spannung
rote LED leuchtet 	Die Oberleitung ist ausgeschaltet. Durch Betätigung des Tasters ● kann die Notfallerdung ausgelöst werden.
rote LED blinkt 	Die Oberleitung ist ausgeschaltet und die Notfallerdung läuft. Rettungsmaßnahmen sind noch nicht möglich.
grüne LED leuchtet 	Der komplette Tunnel ist spannungsfrei und notfallgeerdet.
gelbe LED blinkt 	Der betreffende Tunnelzugang ist spannungsfrei und ordnungsgemäß notfallgeerdet. Die Verbindung zu den anderen Tunnelzugängen ist gestört. Rettungsmaßnahmen erst möglich, wenn alle Tunnelzugänge gelb blinken.

TracFeed® OLSP quick reference guide

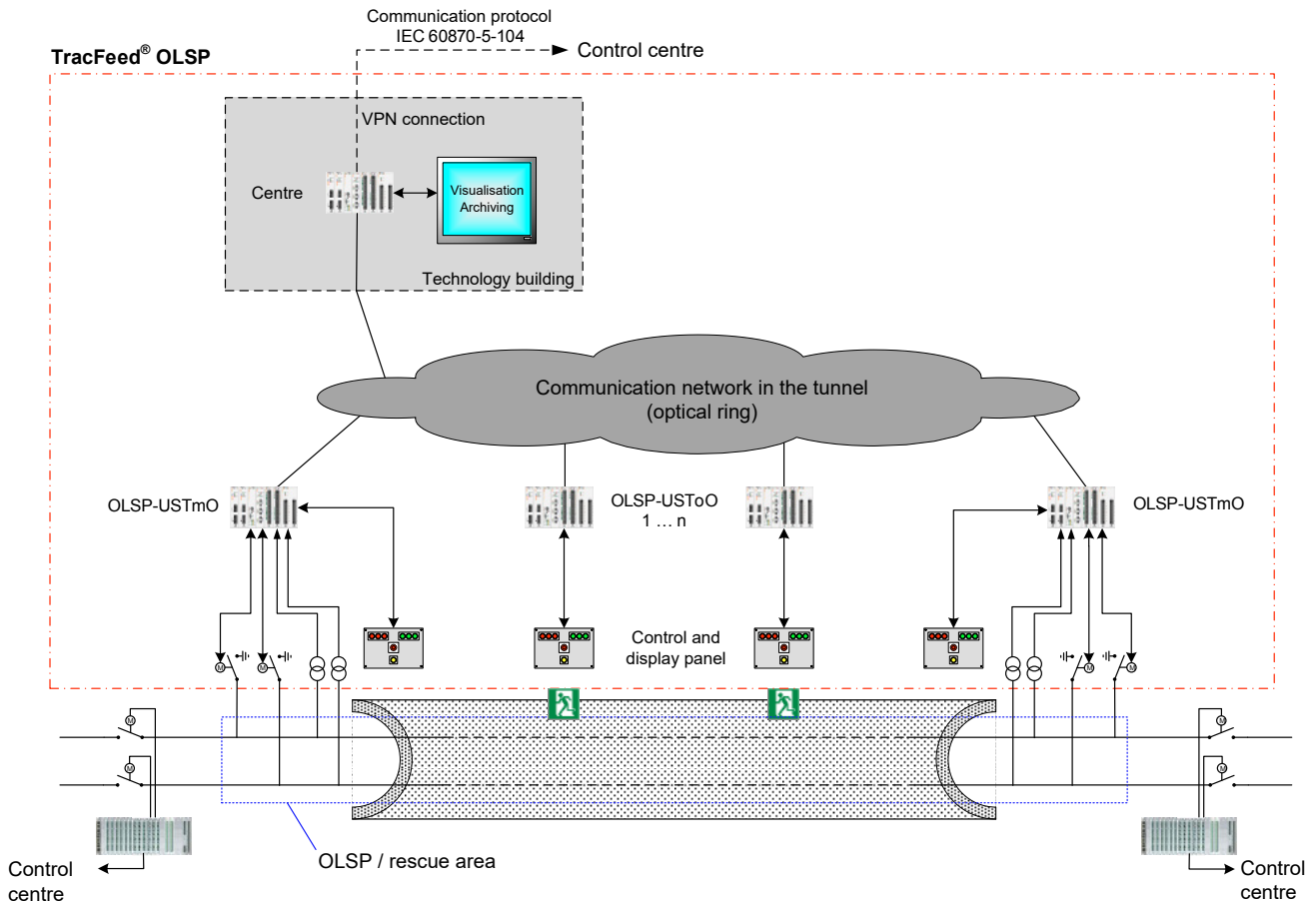

## SERVICE

The service area provides maintenance for the system components. This sustainably increases the main economic factors for the long term, such as quality, performance and availability of the system components. Based on our experience, we know that expert and forward-looking maintenance measures create an enormous potential for savings. Thereby, costly repair measures and failures are permanently avoided.

The aim of maintenance is to operate the systems:

- In perfect working order and
- With the highest possible availability

**The focus is on the economic aspect. In doing so, we support our customers, as we regard efficient maintenance as one of our core competencies.**



In the event of a fault, we are able to restore the availability of the systems quickly by means of our trained service staff.

We provide:

- Inspection/maintenance of substations in accordance with the German Tram Construction and Operation Ordinance (BOStrab)
- Inspection/maintenance of all system components
- Corrective maintenance and repairs
- Improvements
- Service via on-call and stand-by readiness in the event of a fault
- “24 hours a day – 365 days a year”
- Guaranteed agreed reaction times for hotline and on-site assistance



## SELECTED REFERENCE PROJECTS

### Electrification of the ICE depot in Nippes, Cologne

Country: Germany | Customer: DB Fernverkehr AG

Year of the order: 2015 | Completion: 2018

#### Range of services provided by Rail Power Systems:

- Construction of the catenary system: Outdoor system including depot connections as well as
- Inside the depot hall and the external cleaning system
- Overhead conductor rail (OCR)
- 22 km of overhead contact line and 250 large-diameter piling pipe foundations
- Supply line from SP Cologne to the ICE depot
- Emergency power system (EPS) 16.7 Hz
- Protection and control technology for 16.7 Hz switchgear panel
- Design, planning and installing the hall automation, incl. automatic switch-off TracFeed® AEA as per SIL
- Internal power supply: 10 kV distribution systems and 50 Hz LV power supply
- Implementation planning

### Zurich cross-city link, Switzerland

Country: Switzerland | Customer: SBB | Year of the order: 2012

Completion: 2014

ARGE Sersa Technik AG / Balfour Beatty Rail GmbH (the predecessor of Rail Power Systems): Contracted to equip the Weinberg tunnel as a central element of the new Zurich cross-city link from the main station to Oerlikon with an overhead conductor rail (OCR) system, including the transitions to the overhead contact line and a four-track station located in the tunnel under the main station.

#### Range of services provided by Rail Power Systems:

- Design and planning
- Supplying the materials for TracFeed® OSS110
- Providing support during the installation on site
- Design, planning and installing the catenary voltage tester TracFeed® AEE

### Dessau, locomotive test centre, lot 3

Country: Germany | Customer: DB Fahrzeuginstandhaltung GmbH

Year of the order: 2015 | Completion: 2018

Planning, delivery and installation of electrical systems and the construction of a transformer substation

#### Range of services provided by Rail Power Systems:

- Delivery and installation of the electrical equipment for the building of the test centre
- Building earthing and lightning protection, switchgear panel 3 AC 20 kV / 50 Hz
- Low-voltage distribution boards, emergency lighting
- Installation in the building, incl. the office communication system (BKU)
- Fire alarm system, smoke and heat extraction systems (RWA)
- Planning, delivery and assembly of the electrical equipment of vehicle test stands

### Fetesti – Constanta

Country: Romania | Customer: CFR - Compania Națională de Căi Ferate S.A. | Year of the order: 2005 | Completion: 2010

The railway between Fetesti and Constanta is part of the Romanian section of Pan-European Corridor IV. Rail Power Systems undertook the railway electrification package from the planning to the installation and commissioning. The renovation and modernisation included a two-track line of 80 km in total and ten stations on the route.

#### Range of services provided by Rail Power Systems:

- Dismantling of the old catenary; installing the new catenary system, including the masts and foundations
- Securing the tracks and installation
- Laying fibre optic cable along the route
- Providing maintenance vehicles and equipment
- Renovation of two substations 110 kV / 25 kV, the construction and provision of two container substations
- Installation of sectioning points and station equipment
- Design, planning, installing and commissioning the protection and control technology for two substations
- Establishing a SCADA centre for the monitoring and remote control of the line power supply
- Two traction switchgears TracFeed® TAS, transformers
- Protection and control technology for 15 kV and 25 kV MV switchgear panel as per IEC 61850
- Design, planning and installing the hall automation, incl. automatic switch-off TracFeed® AEA
- High voltage test system 1 AC 75 kV / 50 Hz

### Zevenaar, system separation section with voltage detection

Country: The Netherlands | Customer: ProRail B.V.

Year of the order: 2015 | Completion: 2016

In order to reduce the effects of impermissible traffic on the system separation section from the Betouweroute (AC 25 kV, 50 Hz) to the Dutch rail network (DC 1.5 kV), the system separation section was relocated and switched from short-circuit current detection to voltage detection. This enables impermissible traffic to be detected and the power supply can be switched off before a short circuit is triggered.

#### Range of services provided by Rail Power Systems:

- Planning, system analysis and calculations
- Design, planning, delivery and installing the control technology and voltage detection
- Commissioning and approval

### Lohsa, new construction of an inverter station

Country: Germany | Customer: DB Energie GmbH

Year of the order: 2012 | Completion: 2016

Construction of an inverter station (3 x 15 MW), construction of switchgear panels 110, 15 and 10 kV including control and protection technology as well as ancillary systems.

#### Range of services provided by Rail Power Systems:

- General contractor of the project as a consortium GE/RPS
- Delivery and construction of switchgear panels 110 kV / 50 Hz and 15 kV / 16.7 Hz
- Station control technology for 110 kV / 50 Hz high voltage switchgear panel
- Design, planning and installing the higher-level station control technology for the entire inverter station, medium- and low-voltage switchgear panels for on-site power
- Building construction and civil engineering for the inverter, switchgear panels and infrastructure
- Telecommunication, fire extinguishing and burglar alarm systems

### Train depot Rummelsburg (Berlin)

Country: Germany | Customer: DB Fernverkehr AG

Year of the order: 2013 | Completion: 2016

#### Range of services provided by Rail Power Systems:

- Design, planning and installing the hall automation, incl. automatic switch-off TracFeed® AEA as per SIL 2



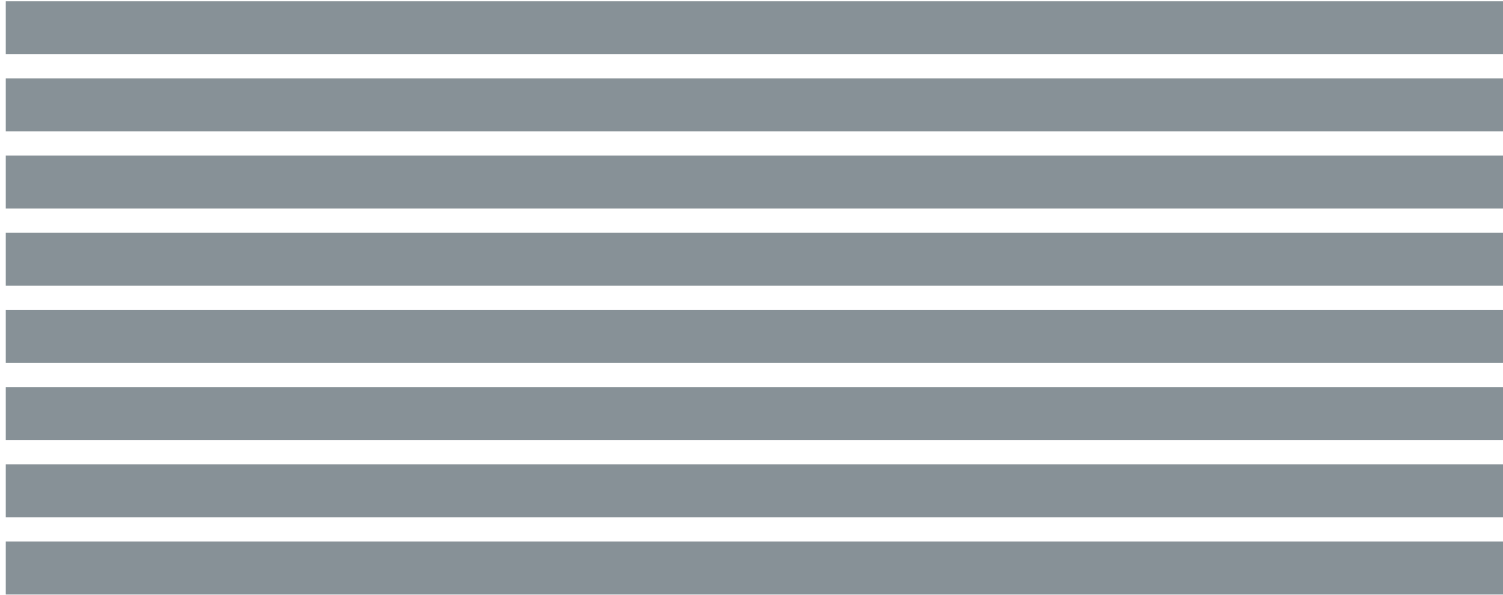

© 2018. All rights reserved by Rail Power Systems GmbH.

The specifications set out in this document apply to conventional applications. They do not represent performance limits. This means that divergent specifications may be attained in specific applications. The contractually agreed specifications or the specifications set out in the specific offer shall exclusively apply. We reserve the right to effect technical modifications. TracFeed® is a registered trademark of Rail Power Systems GmbH.